

6" INLET FLANGE
 1/2" PLATE, 11" O.D.
 (8) 7/8" DIA. HOLES
 ON 9 1/2" B.C. STRADDLE C.L.

6" OUTLET FLANGE
 1/2" PLATE, 11" O.D.
 (8) 7/8" DIA. HOLES
 ON 9 1/2" B.C. STRADDLE C.L.

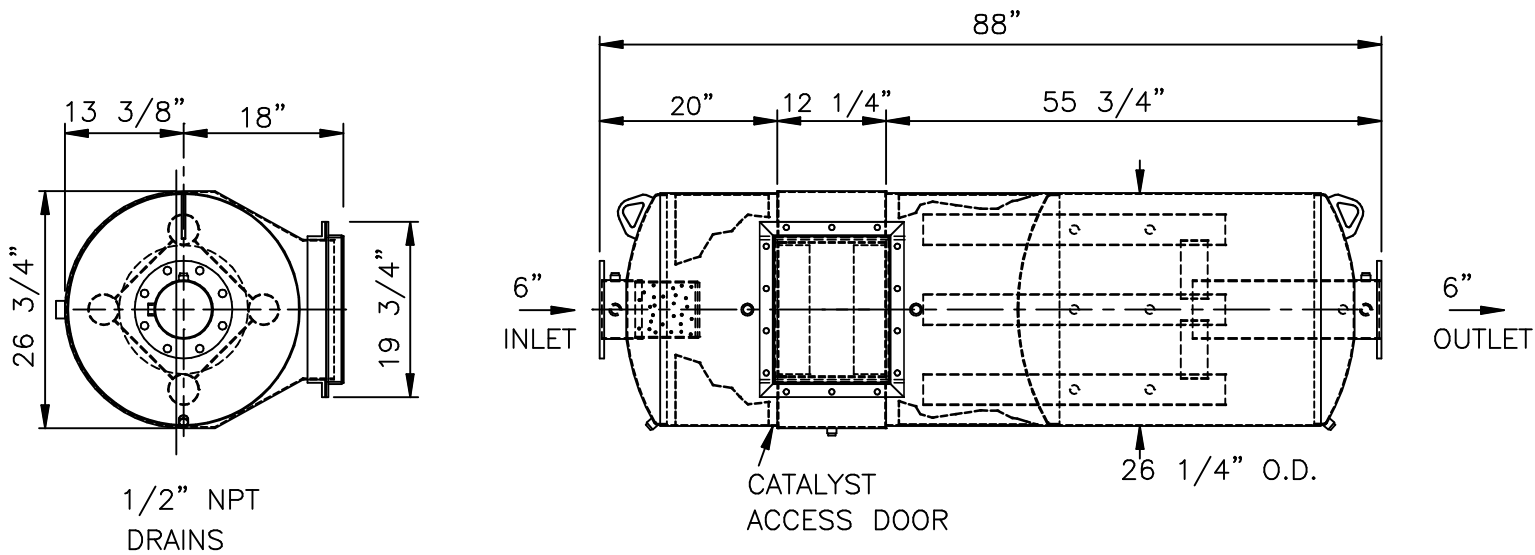

SERVICE: 3 WAY CATALYTIC EXHAUST SILENCER FOR RECIPROCATING ENGINE

| | | | | | | | | |
|----------------|----|-----|-----|-----|----|----|----|----|
| OCTAVE BAND | 63 | 125 | 250 | 500 | 1K | 2K | 4K | 8K |
| INSERTION LOSS | 19 | 30 | 35 | 35 | 30 | 30 | 30 | 30 |

PRESSURE DROP: PER SIZING PROCEDURES

DESTRUCTION EFFICIENCY: PER SIZING PROCEDURES

MATERIALS OF CONSTRUCTION:

- SHELL: 10 GA AND 12 GA CARBON STEEL
- HEADS: 10 GA CARBON STEEL
- CATALYST PANELS: (1) OR (2) 3.5" THICK x 14.5" DIAMETER 304SS
- FLANGES: 1/2" CARBON STEEL

CERTIFICATION

EXTERNAL PAINT: HIGH TEMP BLACK

WEIGHT: 500 LBS.

CUSTOMER: _____

CUSTOMER P.O. NO.: _____

DATE: _____ BY: _____

MAXIM SILENCERS

10635 BRIGHTON LANE
 STAFFORD, TX. 77477
 PHONE (832) 554-0980
 FAX (832) 554-0990

EAC4-29-6 CATALYTIC EXHAUST SILENCER

| | | | | | | | | | |
|-----|-----------|----|------|----------|-----|--------|-----------|---------------|-----|
| No. | REVISIONS | BY | DATE | APPROVED | TJW | 5/7/07 | ORDER NO. | DRAWING NO. | REV |
| | | | | | | | | STD_EAC4-29-6 | |
| | | | | | | | SHEET | | |