

10" INLET FLANGE  
 1/2" PLATE, 16" O.D.  
 (12) 1" DIA. HOLES  
 ON 14 1/4" B.C. STRADDLE C.L.

OPTIONAL DOOR FEATURE PROVIDES  
 TOP OR SIDE ELEMENT ENTRY

10" OUTLET FLANGE  
 1/2" PLATE, 16" O.D.  
 (12) 1" DIA. HOLES  
 ON 14 1/4" B.C. STRADDLE C.L.

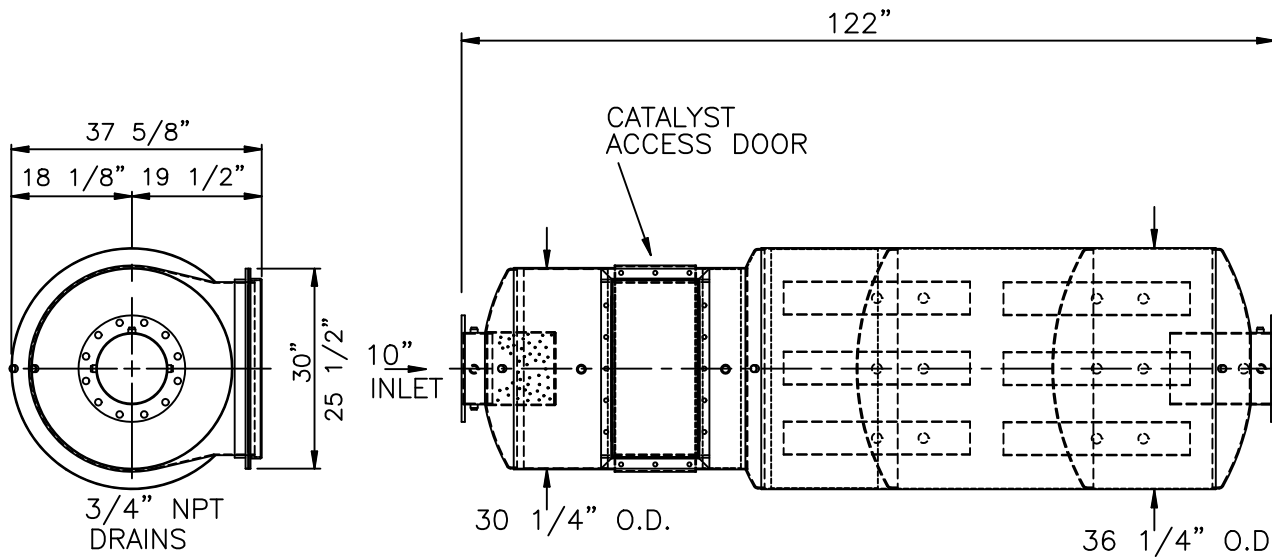

INLET NOZZLE HAS  
 (2) 3/4" FNPT  
 SENSING PORTS AND  
 (1) 18 mm O2 MEASURING PORT

OUTLET NOZZLE HAS  
 (2) 3/4" FNPT  
 SENSING PORTS AND  
 (1) 18 mm O2 MEASURING PORT

SERVICE: CATALYST EXHAUST SILENCER FOR ENGINE

OCTAVE BAND	<u>63</u>	<u>125</u>	<u>250</u>	<u>500</u>	<u>1K</u>	<u>2K</u>	<u>4K</u>	<u>8K</u>
INSERTION LOSS	20	37	37	37	30	30	30	30

SERVICE: CATALYST EXHAUST SILENCER FOR ENGINE

OCTAVE BAND	<u>63</u>	<u>125</u>	<u>250</u>	<u>500</u>	<u>1K</u>	<u>2K</u>	<u>4K</u>	<u>8K</u>
INSERTION LOSS	20	37	37	37	30	30	30	30

MATERIALS OF CONSTRUCTION:

SHELL: 10 GA AND 12 GA CARBON STEEL WITH 16 GA INTERNAL LAMINATIONS  
 HEADS: 3/16" CARBON STEEL  
 CATALYST PANELS: (1) OR (2) 3.5" THICK x 23.5" DIAMETER 304SS  
 FLANGES: 1/2" CARBON STEEL

CERTIFICATION

EXTERNAL PAINT: HIGH TEMP BLACK

WEIGHT: 990 LBS.

CUSTOMER: \_\_\_\_\_

CUSTOMER P.O. NO.: \_\_\_\_\_

DATE: \_\_\_\_\_ BY: \_\_\_\_\_

**MAXIM SILENCERS**

10635 BRIGHTON LANE  
 STAFFORD, TX. 77477  
 PHONE (832) 554-0980  
 FAX (832) 554-0990

EAC4-47-10 CATALYTIC EXHAUST SILENCER

No.	REVISIONS	APPR.	APPROVED	TJW	11/8/07	SHEET	DRAWN	TJW	11/8/07	ORDER NO.	DRAWING NO.	REV
							CHECKED				STD_EAC4-47-10	