

12" INLET FLANGE
 1/2" PLATE, 19" O.D.
 (12) 1" DIA. HOLES
 ON 17"B.C. STRADDLE C.L.

12" OUTLET FLANGE
 1/2" PLATE, 19" O.D.
 (12) 1" DIA. HOLES
 ON 17"B.C. STRADDLE C.L.

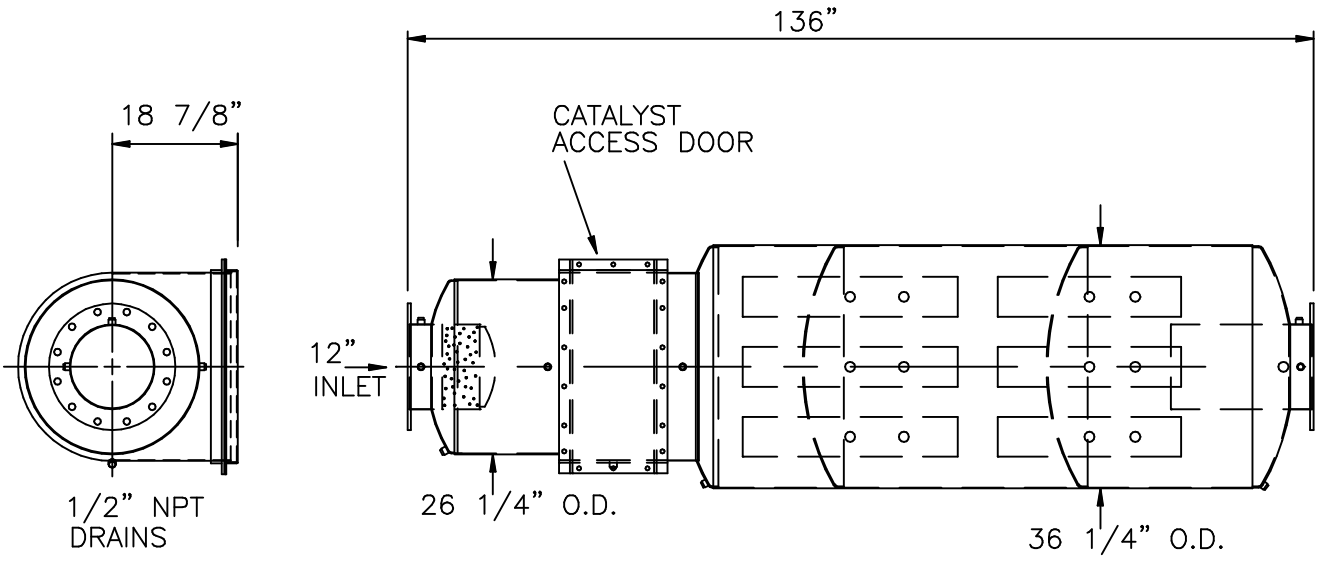

SERVICE: OXIDATION CATALYST EXHAUST SILENCER FOR CAT G3516 ENGINE

| | | | | | | | | |
|----------------|----|-----|-----|-----|----|----|----|----|
| OCTAVE BAND | 63 | 125 | 250 | 500 | 1K | 2K | 4K | 8K |
| INSERTION LOSS | 20 | 37 | 37 | 37 | 30 | 30 | 30 | 30 |

NO CREDIT IS TAKEN FOR INSERTION LOSS OF CATALYST.
 OVERALL DBA INSERTION LOSS = 30 dBA WITHOUT CATALYST, 35 dBA WITH CATALYST.

PRESSURE DROP: AT 7684 CFM, 855°F
 WITH ONE 26.5" DIA x 3.5" THICK CATALYST PANEL 13" H2O

DESTRUCTION EFFICIENCY:
 WITH ONE 26.5" DIA x 3.5" THICK CATALYST PANEL
 0% NOX, 93% CO, 50% NMNEHC, 75% CH2O

MATERIALS OF CONSTRUCTION:

- SHELL: 10 GA AND 12 GA CARBON STEEL
- HEADS: 10 GA AND 3/16" CARBON STEEL
- CATALYST PANELS: (1) OR (2) 3.5" THICK x 26.5" DIAMETER 304SS
- FLANGES: 1/2" CARBON STEEL

CERTIFICATION

EXTERNAL PAINT: HIGH TEMP BLACK

WEIGHT: 1250 LBS.

CUSTOMER: _____
 CUSTOMER P.O. NO.: _____
 DATE: _____ BY: _____

| | | | | | | |
|-----|-----------|-------|----------|-----|---------|---------|
| No. | REVISIONS | APPR. | APPROVED | TJW | 2/15/06 | SHEET 1 |
|-----|-----------|-------|----------|-----|---------|---------|

| | | | |
|------------------------|-----|--|-------------|
| MAXIM SILENCERS | | 10635 BRIGHTON LANE STAFFORD, TX. 77477 PHONE (832) 554-0980 FAX (832) 554-0990 | |
| | | <u>EAC4-53-12 CATALYTIC EXHAUST SILENCER</u> | |
| DRAWN | TJW | 2/15/06 | ORDER NO. |
| CHECKED | | | DRAWING NO. |
| | | | 142-8A11947 |
| | | | REV |