

INLET FLANGE:  
 1/2" PLATE, 14" 150# DRILLING  
 21" O.D. WITH (12) 1 1/8"Ø  
 HOLES ON 18 3/4" B.C.,  
 STRADDLE C.L.

OUTLET FLANGE:  
 1/2" PLATE, 14" 150# DRILLING  
 21" O.D. WITH (12) 1 1/8"Ø  
 HOLES ON 18 3/4" B.C.,  
 STRADDLE C.L.

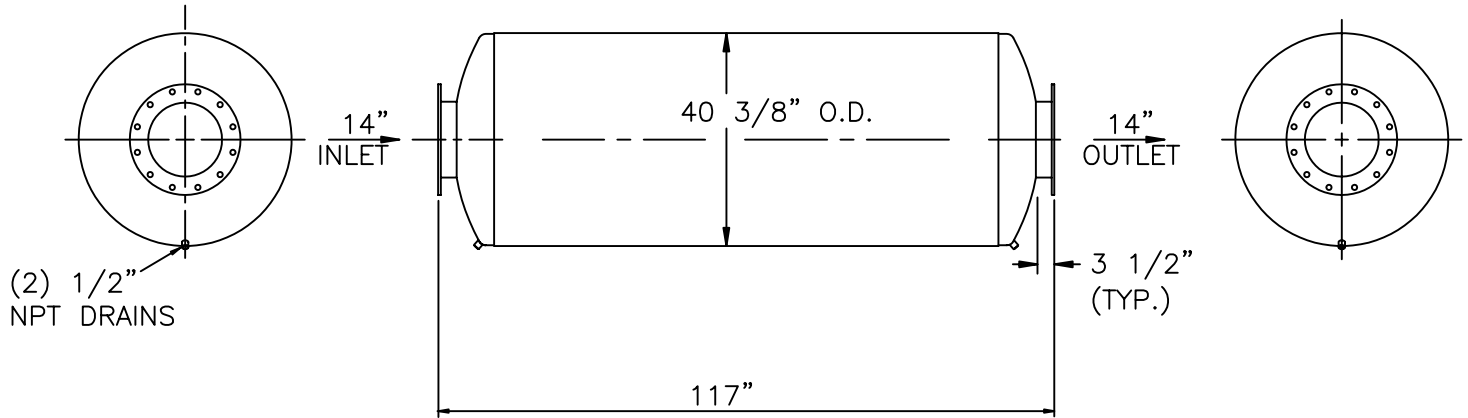

SERVICE : EXHAUST SILENCER FOR RECIPROCATING ENGINE

OCTAVE BAND	63	125	250	500	1K	2K	4K	8K
INSERTION LOSS	28	35	33	26	23	23	24	25

SILENCER PRESSURE DROP: (4.0)\*(Velocity Head In 14' I.D. Duct)

MATERIALS OF CONSTRUCTION: CARBON STEEL

SHELL: 3/16"  
 HEADS AND BAFFLES: 1/4" F&D  
 FLANGES: 1/2" PLATES

CERTIFICATION

EXTERNAL PAINT: FLAT BLACK, HIGH TEMPERATURE

WEIGHT: 1350 LBS

CUSTOMER P.O. NO.: \_\_\_\_\_

DATE: \_\_\_\_\_ BY: \_\_\_\_\_

MAXIM SILENCERS

10635 BRIGHTON LANE  
 STAFFORD, TX 77477  
 PHONE (832) 554-0980  
 FAX (832) 554-0990

14" M41 EXHAUST SILENCER

				DRAWN	TJW	8/12/02	ORDER NO.	DRAWING NO.	REV
				CHECKED	TL	8/12/02		STD_14M41	
No.	REVISIONS	APPR.	APPROVED	TJW	8/12/02			Sheet 1 of 1	