

INLET END VIEW

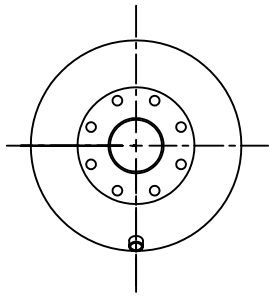

4" INLET FLANGE
1/2" PLATE, 9" O.D.
(8) 3/4" DIA HOLES
ON 7 1/2" B.C.,
STRADDLE C.L.

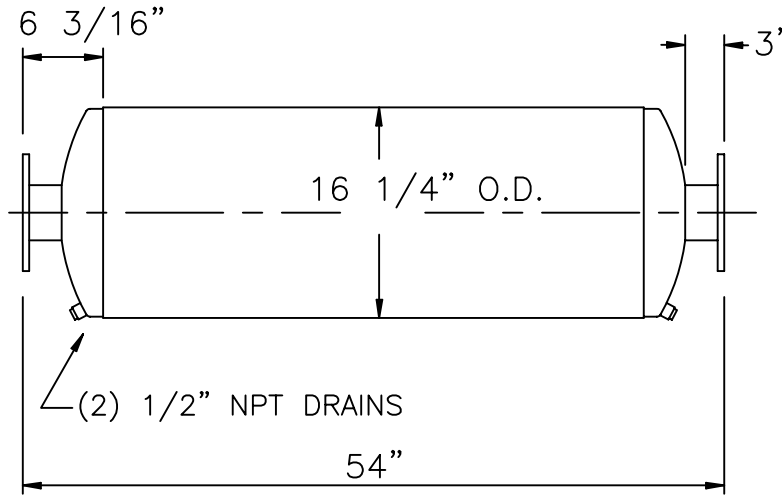

OUTLET END VIEW

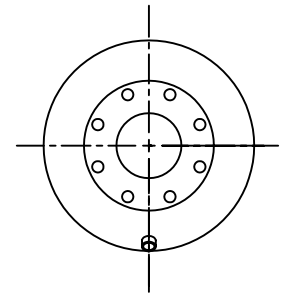

4" OUTLET FLANGE
1/2" PLATE, 9" O.D.
(8) 3/4" DIA HOLES
ON 7 1/2" B.C.,
STRADDLE C.L.

NOTES :

1. SERVICE: EXHAUST SILENCER FOR RECIPROCATING ENGINE
2. NOISE REDUCTION:

OCTAVE BAND	63	125	250	500	1K	2K	4K	8K
ATTENUATION	17	27	35	32	26	23	23	24
3. SILENCER PRESSURE DROP: (4.0)*(Velocity Head In 4" I.D. Duct)
4. MATERIALS OF CONSTRUCTION:
 - SHELL: DOUBLE WRAP 16 GAGE CARBON STEEL
 - HEADS AND BAFFLE: 12 GAGE F&D CARBON STEEL
5. EXTERNAL PAINT: FLAT BLACK, HIGH TEMPERATURE
6. WEIGHT: 120 LBS

CERTIFICATION

CUSTOMER: _____

CUSTOMER P.O. NO.: _____

DATE: _____ BY: _____

MAXIM SILENCERS

10635 BRIGHTON LANE
STAFFORD, TX. 77477
PHONE (832) 554-0980
FAX (832) 554-0990

4" M41 EXHAUST SILENCER

				DRAWN	TJW	9/20/04	ORDER NO.	DRAWING NO.	REV
				CHECKED				STD_4M41	
No.	REVISIONS	APPR.	APPROVED				SHEET		