

12" INLET FLANGE:
 1/2" PLATE, 12" 150# DRILLING
 19" O.D. WITH (12) 1"φ
 HOLES ON 17" B.C.,
 STRADDLE C.L.

12" OUTLET FLANGE:
 1/2" PLATE, 12" 150# DRILLING
 19" O.D. WITH (12) 1"φ
 HOLES ON 17" B.C.,
 STRADDLE C.L.

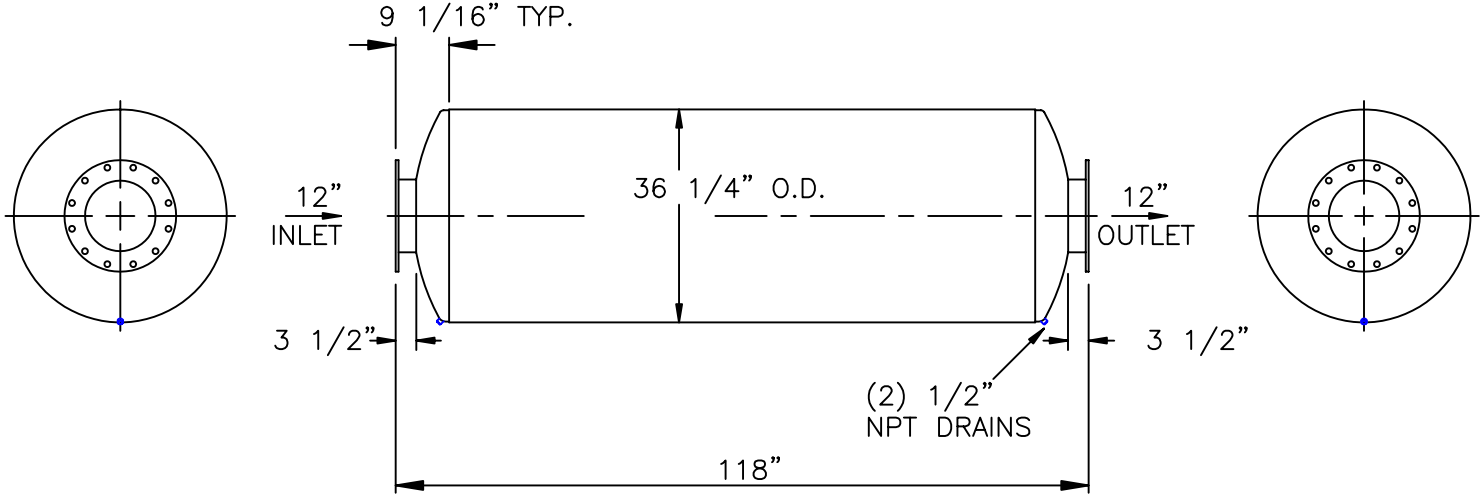

SERVICE: EXHAUST SILENCER FOR RECIPROCATING ENGINE

OCTAVE BAND	31.5	63	125	250	500	1K	2K	4K	8K
INSERTION LOSS	13	24	33	33	27	23	23	24	26

SILENCER PRESSURE DROP:
 (4.0)*(Velocity Head in 12" I.D. Duct)

MATERIALS OF CONSTRUCTION: CARBON STEEL
 SHELL: DOUBLE WRAP 16 GAGE
 HEADS AND BAFFLES: 3/16" F&D
 FLANGES: 1/2" PLATES

CERTIFICATION

EXTERNAL PAINT: HIGH TEMPERATURE BLACK
WEIGHT: 1060 LBS

CUSTOMER: _____
 CUSTOMER P.O. NO.: _____
 DATE: _____ BY: _____

MAXIM SILENCERS 10635 BRIGHTON LANE
 STAFFORD, TX 77477
 PHONE (832) 554-0980
 FAX (832) 554-0990

12" M41 EXHAUST SILENCER

				DRAWN	TJW	2/10/03	ORDER NO.	DRAWING NO.	REV
				CHECKED				12M41_STD	
No.	REVISIONS	APPR.	APPROVED				SHEET	Sheet 1 of 1	