

TOP VIEW

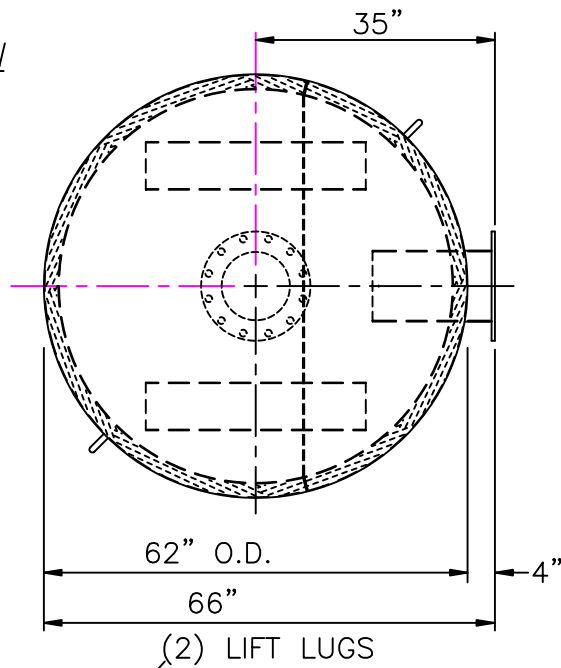

10" OUTLET FLANGE
1/2" PLATE, 16" O.D.
(12) 1" DIA. HOLES
ON 14 1/4" B.C.
STRADDLE C.L.

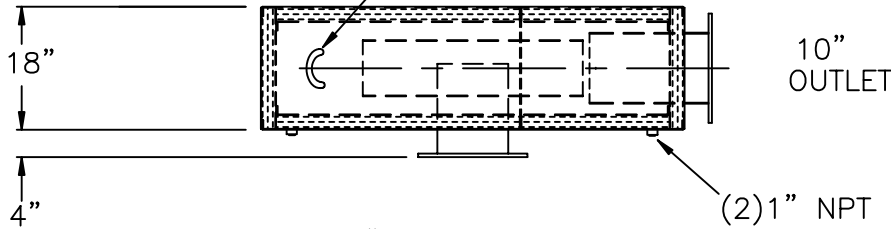

SIDE VIEW

10" INLET FLANGE
1/2" PLATE, 16" O.D.
(12) 1" DIA. HOLES
ON 14 1/4" B.C.
STRADDLE C.L.

(2) 1" NPT
DRAINS
W/PLUGS

SERVICE: EXHAUST SILENCER FOR RECIPROCATING ENGINE

PRESSURE DROP: (4.0)*(VELOCITY HEAD IN 10")

OCTAVE BAND	63	125	250	500	1k	2k	4k	8k
TYPICAL ATTENUATION, dB	20	25	30	34	32	35	35	36

MATERIALS OF CONSTRUCTION:

- SHELL: 12 GAGE CARBON STEEL
- HEADS: 10 GAGE CARBON STEEL
- PERFO: 12 GA C.S.
- PACKING: 2" FIBERGLASS (TOP, BOTTOM, SIDE WALL)

EXTERNAL PAINT: HIGH TEMP BLACK

WEIGHT: 831 LBS.

CERTIFICATION

CUSTOMER: _____

CUSTOMER P.O. NO.: _____

DATE: _____ BY: _____

MAXIM SILENCERS

10635 BRIGHTON LANE
STAFFORD, TX. 77477
832-554-0980
FAX (832) 554-0990

10"MD36 COMPACT EXHAUST SILENCER
(SUPER-CRITICAL GRADE, INTERNALLY INSULATED)

DRAWN	TJW	3/5/04	ORDER NO.	DRAWING NO.	REV
CHECKED				STD_10MD36	
No.	REVISIONS	APPR. APPROVED	TJW	3/5/04	