

14" OUTLET FLANGE:
 14" 150# DRILLING
 1/2" PLATE, 21" O.D.
 WITH (12) 1 1/8" DIA. HOLES
 ON 18 3/4" B.C.
 STRADDLE CENTERLINE

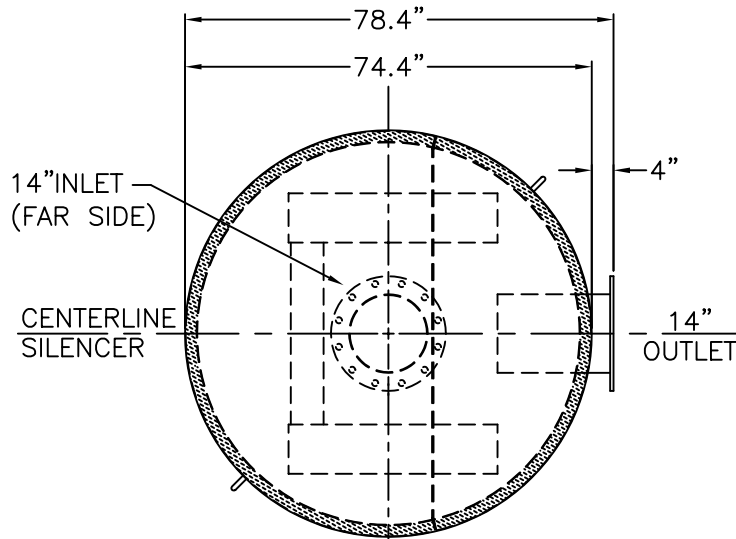

TOP VIEW

2" OF INTERNAL
 INSULATION ON
 ALL WALLS

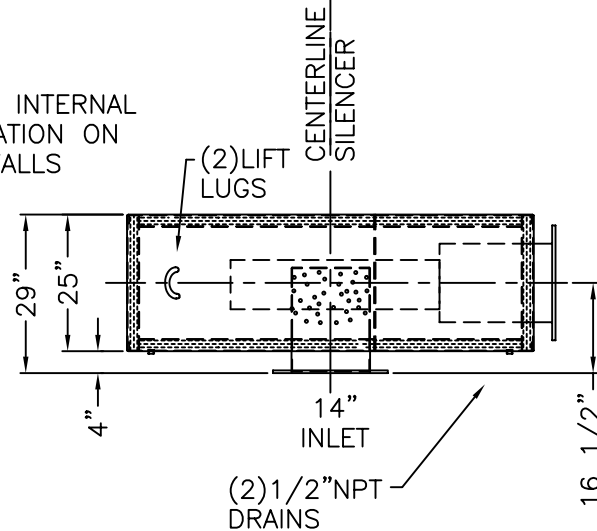

14" OUTLET
 SIDE VIEW

SERVICE: EXHAUST SILENCER FOR RECIPROCATING ENGINE
PRESSURE DROP: (4.0)*(VELOCITY HEAD IN 14")

OCTAVE BAND	63	125	250	500	1k	2k	4k	8k
TYPICAL ATTENUATION, dB	18	25	32	35	35	35	32	30

MATERIALS OF CONSTRUCTION:

- SHELL: 12 GA. C.S.
- HEADS: 10 GA. C.S.
- PERFO: 12 GA C.S.
- PACKING: 2" FIBERGLASS (TOP, BOTTOM, SIDE WALL)

EXTERNAL PAINT: HIGH TEMP BLACK

WEIGHT: 1500 LBS.

14" INLET FLANGE:
 14" 150# DRILLING
 1/2" PLATE, 21" O.D.
 WITH (12) 1 1/8" DIA. HOLES
 ON 18 3/4" B.C.
 STRADDLE CENTERLINE

CERTIFICATION

CUSTOMER: _____

CUSTOMER P.O. NO.: _____

DATE: _____ BY: _____

MAXIM SILENCERS

10635 BRIGHTON LANE
 STAFFORD, TX 77477
 PHONE (832) 554-0980
 FAX (832) 554-0990

14" MD36 COMPACT EXHAUST SILENCER

DRAWN	DG	10/21/05	ORDER NO.	DRAWING NO.	REV
CHECKED	RS	10/21/05		STD_14MD36	
No.	REVISIONS	APPR. APPROVED	JJ	10/21/05	Sheet 1 of 1