

TOP VIEW

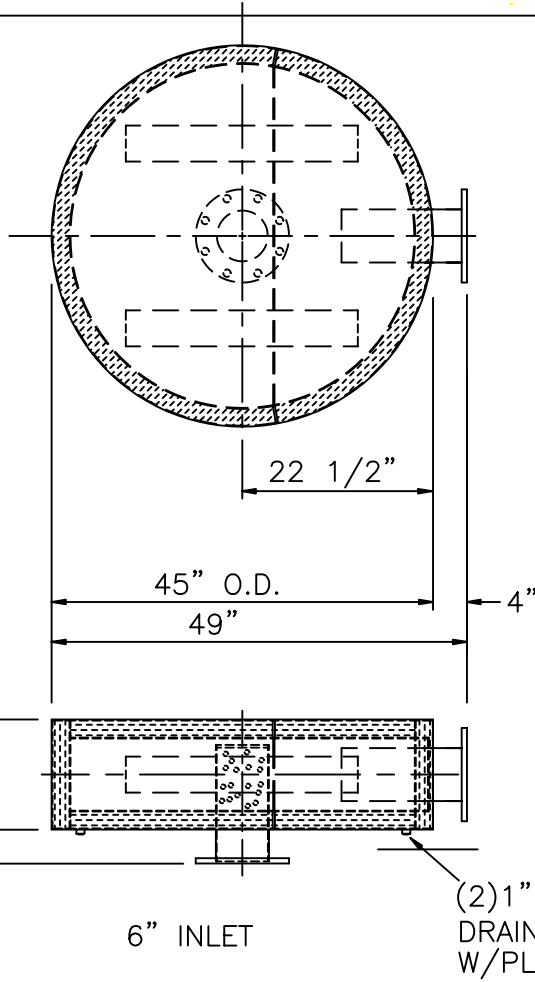

6" OUTLET FLANGE
 1/2" PLATE, 11" O.D.
 (8) 7/8" DIA. HOLES
 ON 9 1/2" B.C.
 STRADDLE C.L.

SIDE VIEW

6" INLET FLANGE
 1/2" PLATE, 11" O.D.
 (8) 7/8" DIA. HOLES
 ON 9 1/2" B.C.
 STRADDLE C.L.

MATERIALS OF CONSTRUCTION:

- SHELL: 12 GAGE CARBON STEEL
- HEADS: 10 GAGE CARBON STEEL
- PERFO: 12 GA CARBON STEEL
- PACKING: 2" FIBERGLASS (TOP, BOTTOM, SIDE WALL)

NOISE REDUCTION: 33-37 dBA OVERALL

PRESSURE DROP: (4.0)*(VELOCITY HEAD IN 6")

EXTERNAL PAINT: HIGH TEMP. BLACK

WEIGHT: 440 LBS.

CERTIFICATION

CUSTOMER: _____

CUSTOMER P.O. NO.: _____

DATE: _____ BY: _____

MAXIM SILENCERS

10635 BRIGHTON LANE
 STAFFORD, TX 77477
 PHONE (832) 554-0980
 FAX (832) 554-0990

6"MD36 COMPACT EXHAUST SILENCER
 (SUPER CRITICAL GRADE, INTERNALLY INSULATED)

DRAWN	TJW	5/4/04	ORDER NO.	DRAWING NO.	REV
-------	-----	--------	-----------	-------------	-----

CHECKED				142-8A11583	
---------	--	--	--	-------------	--

No.	REVISIONS	APPR.	APPROVED		
-----	-----------	-------	----------	--	--