

28" INLET FLANGE
 5/8" PLATE, 36 1/2" O.D.
 (28) 1 3/8" DIA HOLES
 ON 34" B.C.
 STRADDLE C.L.

28" OUTLET FLANGE
 5/8" PLATE, 36 1/2" O.D.
 (28) 1 3/8" DIA HOLES
 ON 34" B.C.
 STRADDLE C.L.

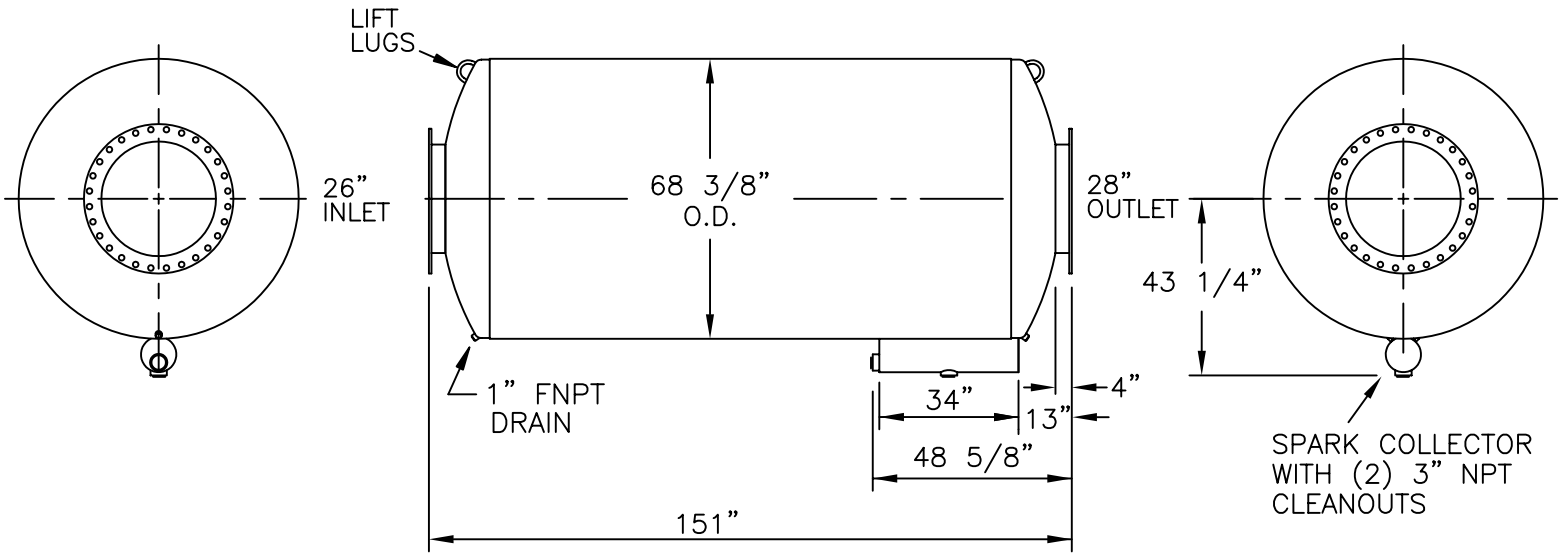

NOTES :

1. SERVICE: SPARK ARRESTING EXHAUST SILENCER FOR ENGINE
2. NOISE REDUCTION : 20 DBA

OCTAVE BAND	<u>63</u>	<u>125</u>	<u>250</u>	<u>500</u>	<u>1K</u>	<u>2K</u>	<u>4K</u>	<u>8K</u>
ATTENUATION	19	27	23	18	16	16	17	20
3. SILENCER PRESSURE DROP: (4.0)*(Velocity Head)
 IN 28" I.D. DUCT
4. MATERIALS OF CONSTRUCTION :
 SHELL : 3/16" CARBON STEEL
 HEADS AND BAFFLE : 1/4" CARBON STEEL
5. EXTERNAL PAINT : HIGH TEMP. BLACK
6. WEIGHT: 3840 LBS

CERTIFICATION

CUSTOMER: _____

CUSTOMER P.O. NO.: _____

DATE: _____ BY: _____

MAXIM SILENCERS

10635 BRIGHTON LANE
 STAFFORD, TX 77477
 PHONE (832) 554-0980
 FAX (832) 554-0990

28" MSA1 EXHAUST SILENCER

				DRAWN	TJW	1/30/02	ORDER NO.	DRAWING NO.	REV
				CHECKED				STD28MSA1	
No.	REVISIONS	APPR.	APPROVED						