

30" INLET FLANGE  
 5/8" PLATE, 38 3/4" O.D.  
 (28) 1 3/8" DIA HOLES  
 ON 36" B.C.,  
 STRADDLE C.L.

30" OUTLET FLANGE  
 5/8" PLATE, 38 3/4" O.D.  
 (28) 1 3/8" DIA HOLES  
 ON 36" B.C.,  
 STRADDLE C.L.

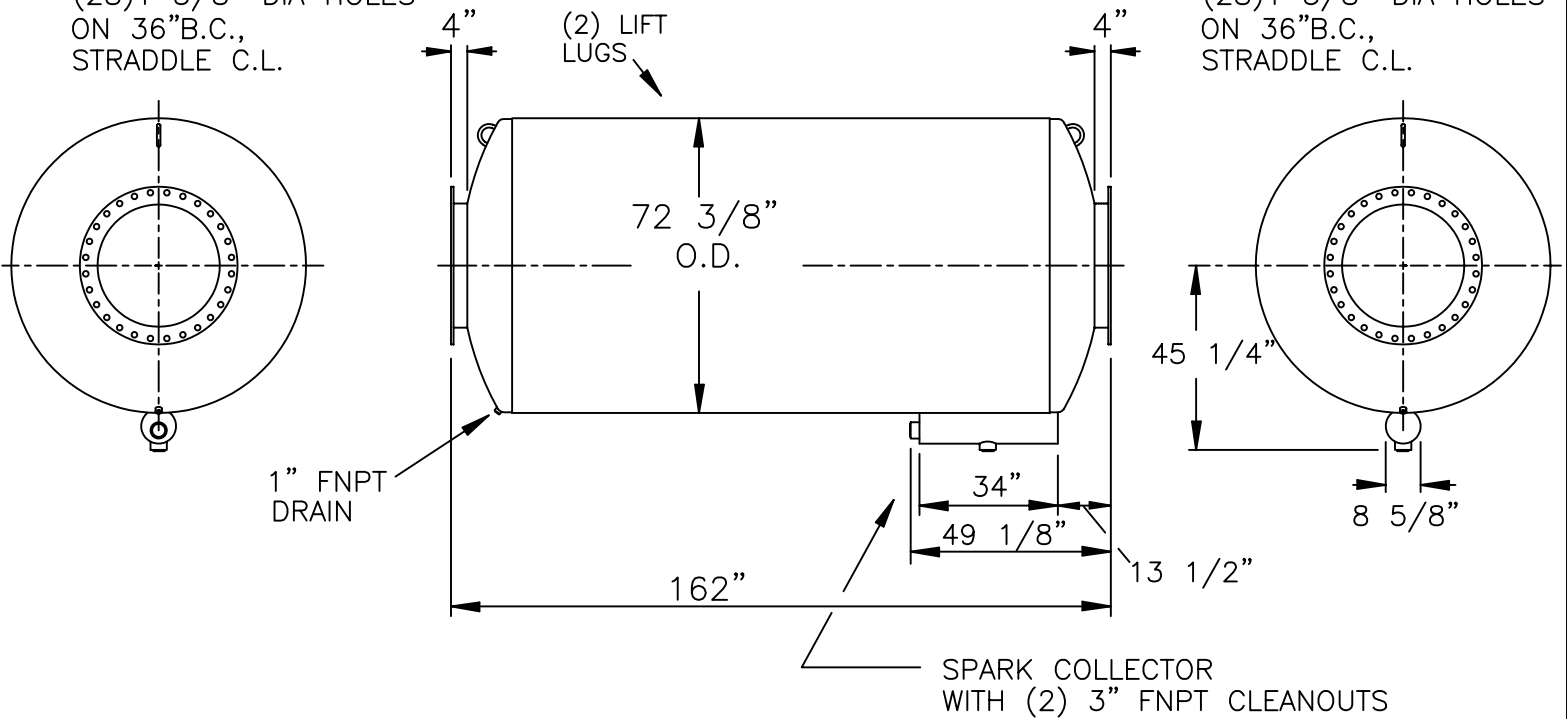

NOTES :

1. SERVICE: SPARK ARRESTING EXHAUST SILENCER FOR RECIPROCATING ENGINE
2. NOISE REDUCTION : 20 DBA  
 OCTAVE BAND 63 125 250 500 1K 2K 4K 8K  
 ATTENUATION 20 27 25 19 16 17 18 21
3. SILENCER PRESSURE DROP: (4)(Velocity Head In 30" I.D.Duct)
4. MATERIALS OF CONSTRUCTION:  
 SHELL : 3/16" CARBON STEEL  
 HEADS AND BAFFLE : 1/4" CARBON STEEL
5. EXTERNAL PAINT : HIGH TEMP. BLACK
6. WEIGHT : 4470 LBS

CERTIFICATION

CUSTOMER: \_\_\_\_\_

CUSTOMER P.O. NO.: \_\_\_\_\_

DATE: \_\_\_\_\_ BY: \_\_\_\_\_

MAXIM SILENCERS

10635 BRIGHTON LANE  
 STAFFORD, TX 77477  
 PHONE (832) 554-0980  
 FAX (832) 554-0990

30"MSA1 SPARK ARRESTING  
 EXHAUST SILENCER

				DRAWN	TJW	3/22/01	ORDER NO.	DRAWING NO.	REV
				CHECKED				STD30MSA1	
No.	REVISIONS	APPR.	APPROVED				SHEET		