

20" INLET FLANGE
 5/8" PLATE, 27 1/2" O.D.
 (20) 1 1/4" DIA HOLES
 ON 25" B.C.
 STRADDLE C.L.

20" OUTLET FLANGE
 5/8" PLATE, 27 1/2" O.D.
 (20) 1 1/4" DIA HOLES
 ON 25" B.C.
 STRADDLE C.L.

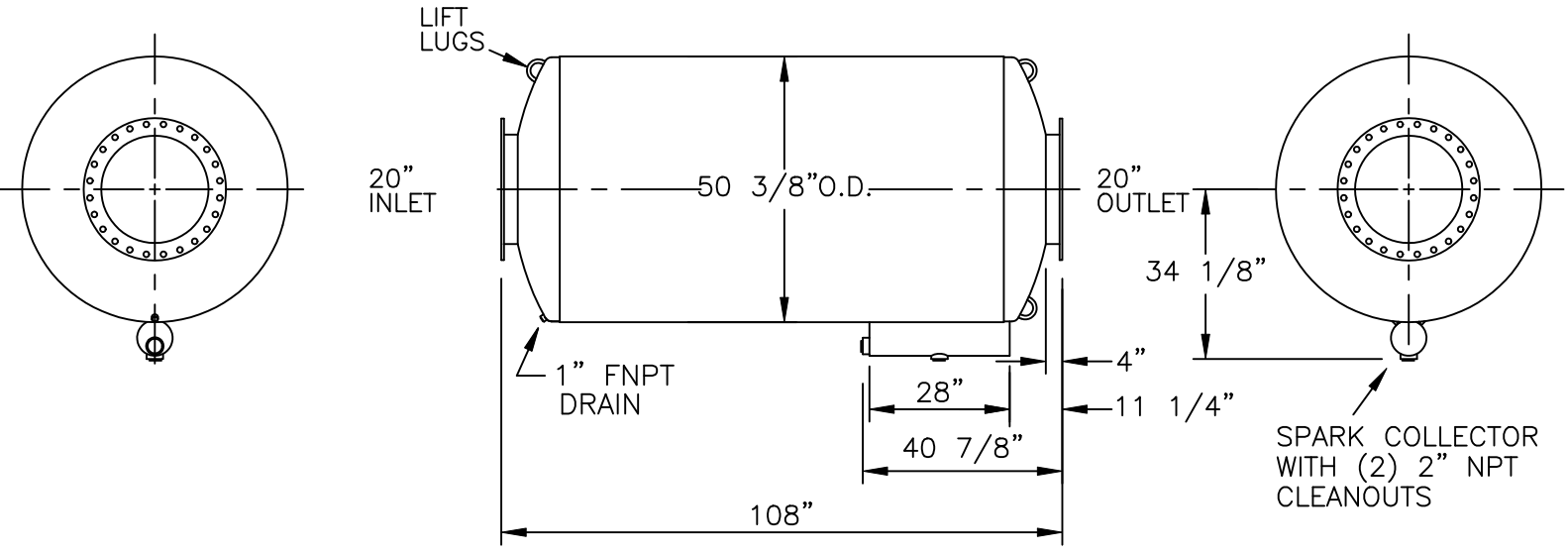

NOTES :

1. SERVICE: SPARK ARRESTING EXHAUST SILENCER FOR ENGINE
2. NOISE REDUCTION : 20 DBA

OCTAVE BAND	63	125	250	500	1K	2K	4K	8K
ATTENUATION	15	25	26	20	16	16	16	18
3. SILENCER PRESSURE DROP: (4.0)*(Velocity Head)
 IN 20" I.D. DUCT
4. MATERIALS OF CONSTRUCTION :
 SHELL : 3/16" CARBON STEEL
 HEADS AND BAFFLE : 1/4" CARBON STEEL
5. EXTERNAL PAINT : HIGH TEMP. BLACK
6. WEIGHT: 1790 LBS

CERTIFICATION

CUSTOMER: _____
 CUSTOMER P.O. NO.: _____

 DATE: _____ BY: _____

MAXIM
 SILENCERS, INC.

10635 BRIGHTON LANE
 STAFFORD, TEXAS 77477
 PHONE (832) 554-0980
 FAX (832) 554-0990

20"MSA1 EXHAUST SILENCER

			DRAWN	JJ	9/10/08	ORDER NO.	DRAWING NO.	REV
			CHECKED				20MSA1_STD	
No.	REVISIONS	APPR.	APPROVED					