

18" INLET FLANGE
 5/8" PLATE, 25" O.D.
 (16) 1 1/4" DIA HOLES
 ON 22 3/4" B.C.,
 STRADDLE VERTICAL C.L.

18" OUTLET FLANGE
 5/8" PLATE, 25" O.D.
 (16) 1 1/4" DIA HOLES
 ON 22 3/4" B.C.,
 STRADDLE VERTICAL C.L.

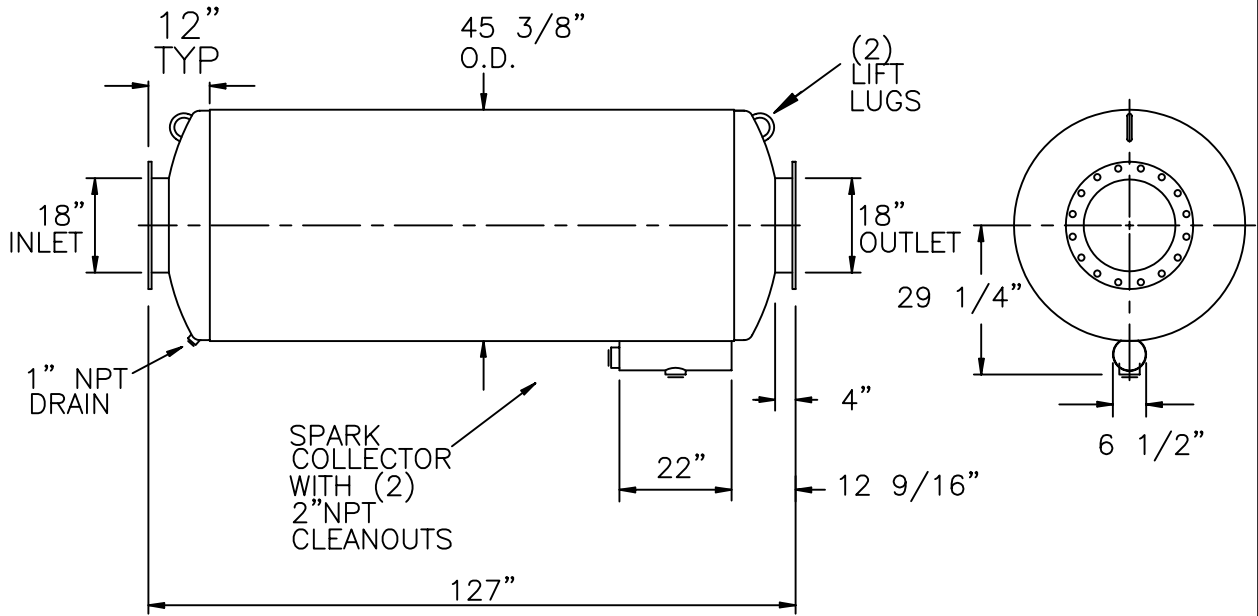

NOTES:

SERVICE: SPARK ARRESTING EXHAUST SILENCER
 FOR RECIPROCATING ENGINE

PRESSURE DROP: (4.0)*(VELOCITY HEAD IN 18" I.D. DUCT)

OCTAVE BAND	63	125	250	500	1k	2k	4k	8k
ATTENUATION, dB	19	30	30	24	20	19	21	23

MATERIALS OF CONSTRUCTION :

SHELL : 3/16" CARBON STEEL
 HEADS AND BAFFLE : 1/4" CARBON STEEL

EXTERNAL PAINT: HIGH TEMPERATURE BLACK

CERTIFICATION

WEIGHT: 1850 LBS

CUSTOMER: _____

CUSTOMER P.O. NO.: _____

DATE: _____

BY: _____

MAXIM SILENCERS

10635 BRIGHTON LANE
 STAFFORD, TX, 77477
 PHONE (832) 554-0980
 FAX (832) 554-0990

18"MSA2 EXHAUST SILENCER

No.	REVISIONS	APPR.	APPROVED	DRAWN	TJW	2/25/02	ORDER NO.	DRAWING NO.	REV
				CHECKED				STD_18MSA2	
							SHEET		