

8" INLET FLANGE
 1/2" PLATE, 13 1/2" O.D.
 (8) 7/8" DIA HOLES
 ON 11 3/4" B.C.,
 STRADDLE VERTICAL C.L.

8" OUTLET FLANGE
 1/2" PLATE, 13 1/2" O.D.
 (8) 7/8" DIA HOLES
 ON 11 3/4" B.C.,
 STRADDLE VERTICAL C.L.

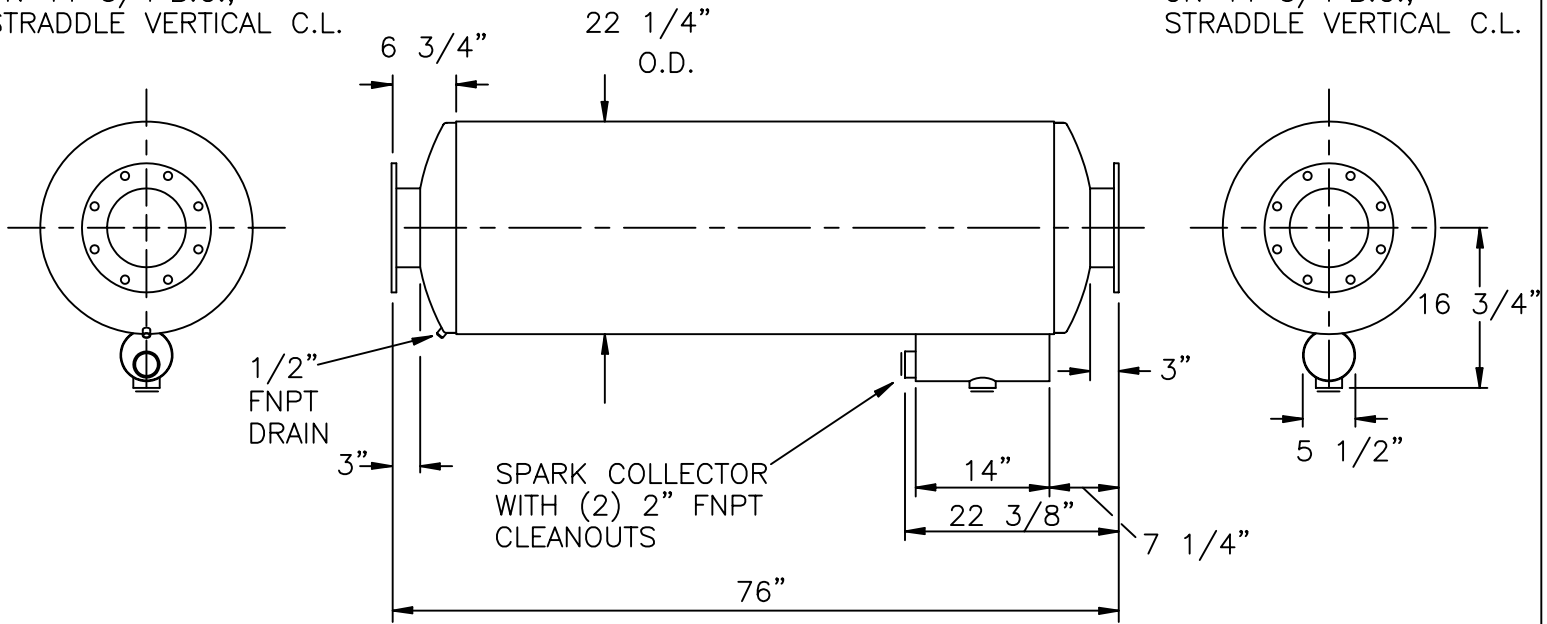

NOTES :

1. SERVICE: SPARK ARRESTING EXHAUST SILENCER FOR RECIPROCATING ENGINE
2. PRESSURE DROP: (4.0)* (Velocity Head In 8" I.D. Duct)
3. OCTAVE BAND ATTENUATION, dB

63	125	250	500	1k	2k	4k	8k
14	23	31	27	22	19	19	22
4. MATERIALS OF CONSTRUCTION:
 SHELL: 12 GAGE CARBON STEEL
 HEADS AND BAFFLE: 10 GA. CARBON STEEL
5. EXTERNAL PAINT: HIGH TEMPERATURE BLACK
6. WEIGHT: 285 LBS

CERTIFICATION

CUSTOMER: _____

CUSTOMER P.O. NO.: _____

DATE: _____ BY: _____

MAXIM SILENCERS

10635 BRIGHTON LANE
 STAFFORD, TX. 77477
 PHONE (832) 554-0980
 FAX (832) 554-0990

8"MSA2 SPARK ARRESTING EXHAUST SILENCER

					DRAWN	TJW	10/15/01	ORDER NO.	DRAWING NO.	REV
					CHECKED				STD_8MSA2	
No.	REVISIONS	APPR.	APPROVED							