

INLET AND OUTLET FLANGES:  
 1/2" PLATE, 12" 150# DRILLING  
 19" O.D. WITH (12) 1"φ  
 HOLES ON 17" B.C.,  
 STRADDLE C.L.

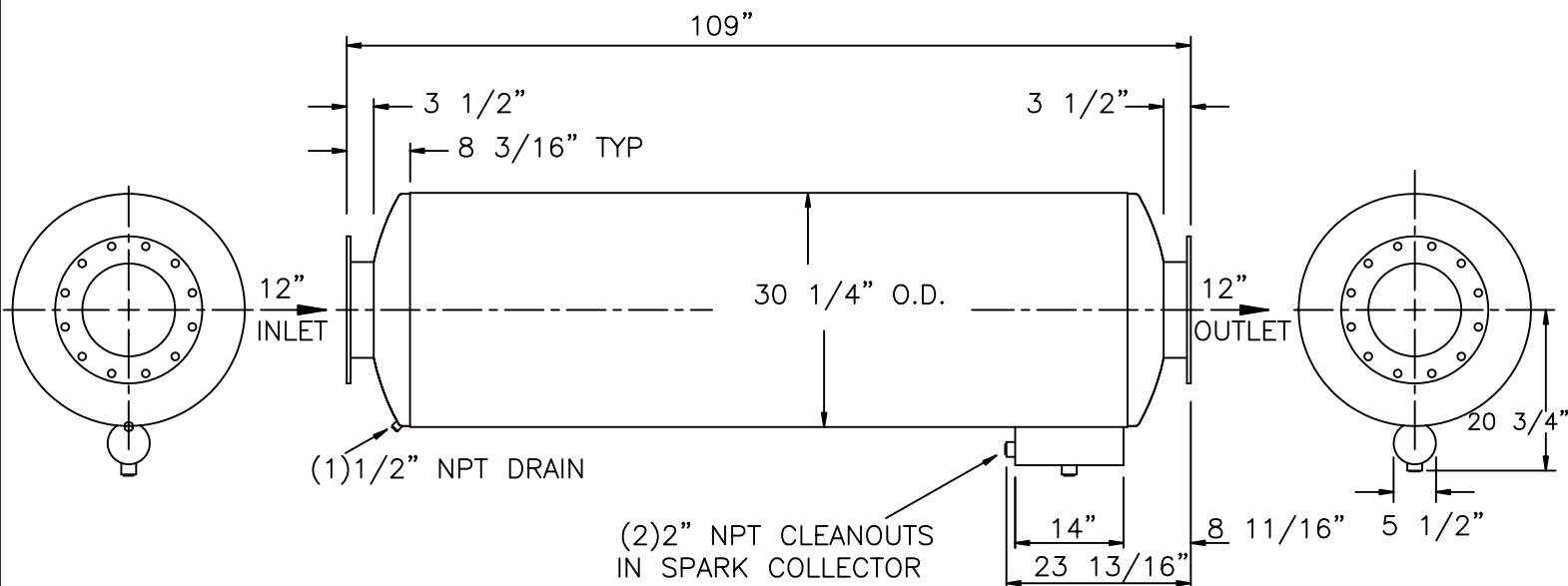

SERVICE : SPARK ARRESTING EXHAUST SILENCER FOR RECIPROCATING ENGINE

OCTAVE BAND	63	125	250	500	1K	2K	4K	8K
INSERTION LOSS	20	30	29	24	20	19	20	22

SILENCER PRESSURE DROP: 4\*Velocity Head in 12" Duct

MATERIALS OF CONSTRUCTION: CARBON STEEL

SHELL: 12 GAGE CARBON STEEL  
 HEADS AND BAFFLES: 3/16", F&D  
 FLANGES: 1/2" PLATE

EXTERNAL PAINT: FLAT BLACK, HIGH TEMPERATURE

WEIGHT: 745 LBS

CERTIFICATION

CUSTOMER: \_\_\_\_\_

CUSTOMER P.O. NO.: \_\_\_\_\_

DATE: \_\_\_\_\_ BY: \_\_\_\_\_

MAXIM SILENCERS

10635 BRIGHTON LANE  
 STAFFORD, TX. 77477  
 PHONE (832) 554-0980  
 FAX (832) 554-0990

12"MSA2 SPARK ARRESTING EXHAUST SILENCER

DRAWN	TJW	6/17/04	ORDER NO.	DRAWING NO.	REV
-------	-----	---------	-----------	-------------	-----

CHECKED				STD_12MSA2	
---------	--	--	--	------------	--

No.	REVISIONS	APPR.	APPROVED			Sheet 1 of 1
-----	-----------	-------	----------	--	--	--------------