

8" OUTLET FLANGE  
 1/2" PLATE, 13 1/2" O.D.  
 (8) 7/8" DIA. HOLES  
 ON 11 3/4" B.C.  
 STRADDLE C.L.

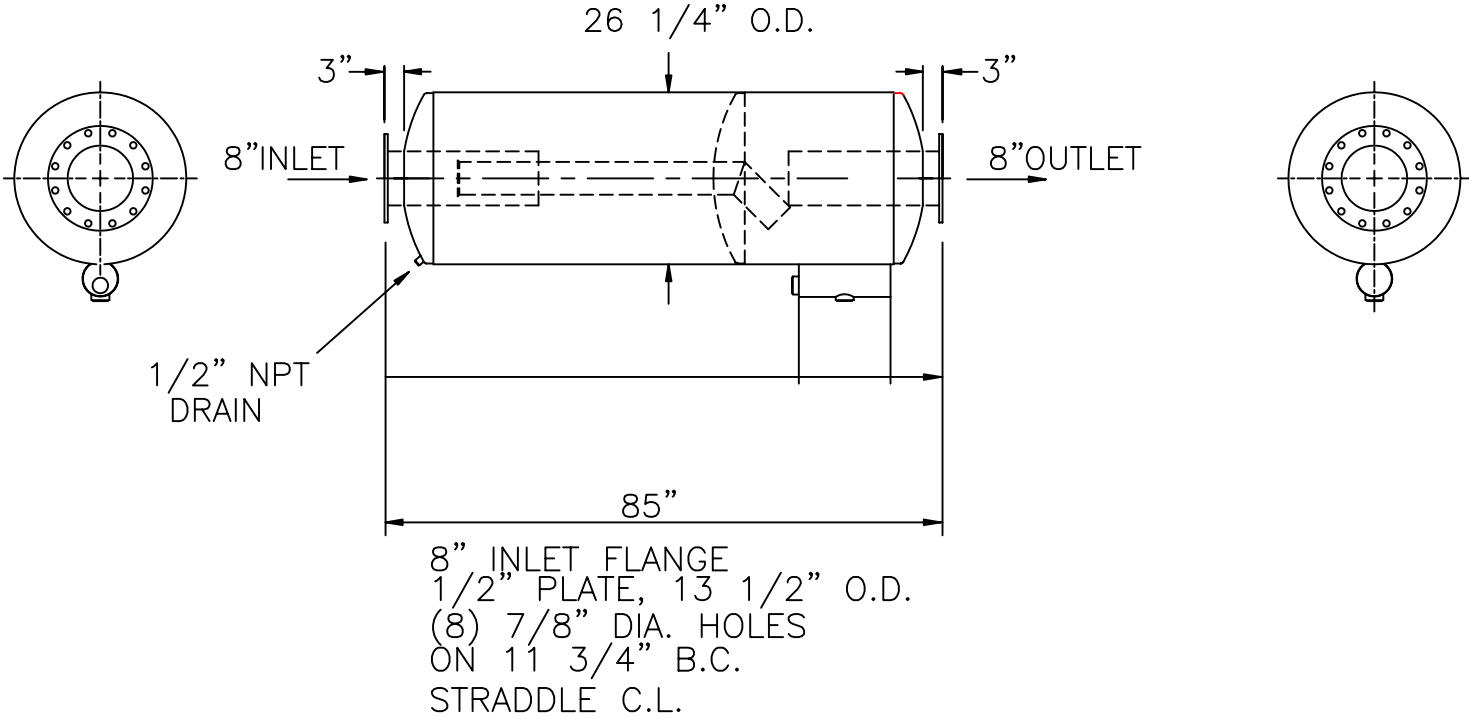

SERVICE: SPARK ARRESTING EXHAUST SILENCER FOR ENGINE

OCTAVE BAND	63	125	250	500	1K	2K	4K	8K
INSERTION LOSS	19	30	35	30	25	23	23	25

PRESSURE DROP: 6\*Velocity Head In 8" I.D. Duct

MATERIALS OF CONSTRUCTION :  
 SHELL : DOUBLE WRAP 16 GA CARBON STEEL  
 HEADS : 10 GAGE CARBON STEEL

CERTIFICATION

CUSTOMER: \_\_\_\_\_  
 CUSTOMER P.O. NO.: \_\_\_\_\_  
 DATE: \_\_\_\_\_ BY: \_\_\_\_\_

EXTERNAL PAINT: HIGH TEMP BLACK

WEIGHT: 420 LBS.

				MAXIM SILENCERS		10635 BRIGHTON LANE STAFFORD, TX 77477 PHONE (832) 554-0980 FAX (832) 554-0990			
				<u>8"MSA3 EXHAUST SILENCER</u>					
				DRAWN	TJW	11/1/02	ORDER NO.	DRAWING NO.	REV
				CHECKED				STD8MSA3	
No.	REVISIONS	APPR.	APPROVED						