

6" INLET FLANGE
 1/2" PLATE, 11" O.D.
 (8) 7/8" DIA. HOLES
 ON 9 1/2" B.C.
 STRADDLE C.L.

6" OUTLET FLANGE
 1/2" PLATE, 11" O.D.
 (8) 7/8" DIA. HOLES
 ON 9 1/2" B.C.
 STRADDLE C.L.

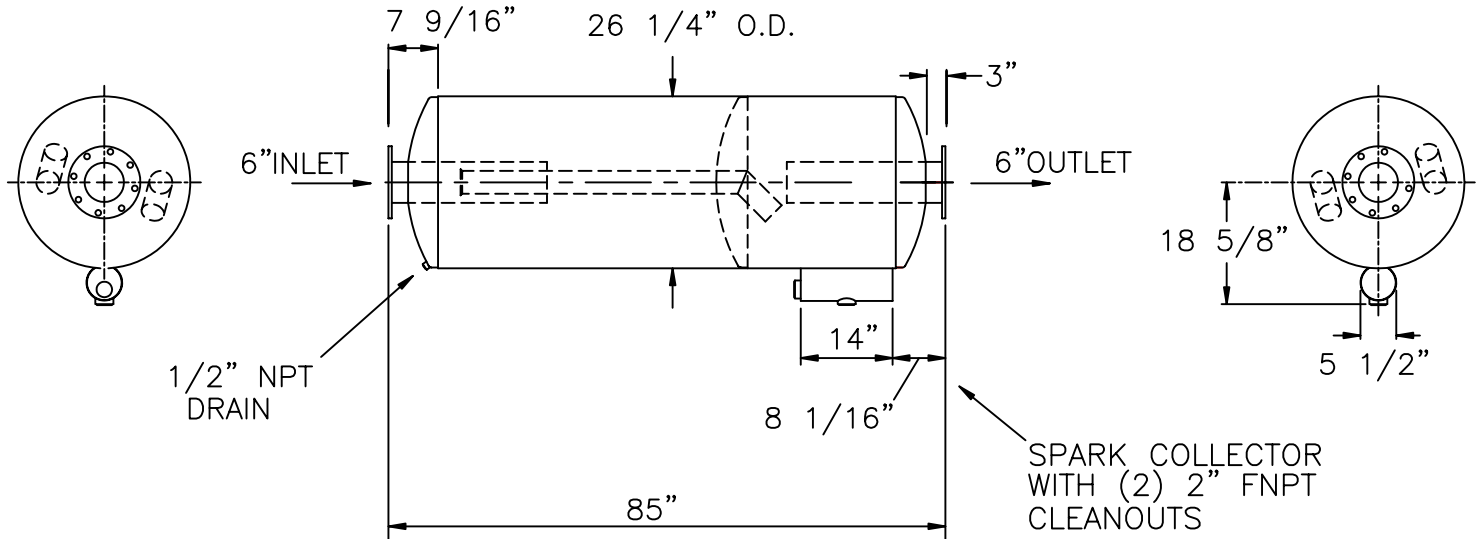

SERVICE: SPARK ARRESTING EXHAUST SILENCER FOR ENGINE

OCTAVE BAND	63	125	250	500	1K	2K	4K	8K
INSERTION LOSS	19	30	35	35	31	28	28	28

PRESSURE DROP: 6*Velocity Head In 6" I.D. Duct

MATERIALS OF CONSTRUCTION :

SHELL : DOUBLE WRAP 16 GA CARBON STEEL
 HEADS : 10 GAGE CARBON STEEL

CERTIFICATION

CUSTOMER: _____

CUSTOMER P.O. NO.: _____

EXTERNAL PAINT: HIGH TEMP BLACK

WEIGHT: 390 LBS.

DATE: _____ BY: _____

MAXIM SILENCERS

10635 BRIGHTON LANE
 STAFFORD, TX 77477
 PHONE (832) 554-0980
 FAX (832) 554-0990

6"MSA4 EXHAUST SILENCER

				DRAWN	TJW	12/10/02	ORDER NO.	DRAWING NO.	REV
				CHECKED				STD6MSA4	
No.	REVISIONS	APPR.	APPROVED						